

ANNOUNCED SPECIFICATION OF HS-5125MG SLIM DIGITAL SERVO

1. TECHNICAL VALUES

CONTROL SYSTEM	:+PULSE WIDTH CONTROL 1500usec NEUTRAL	
OPERATING VOLTAGE RANGE	:4.8V TO +6.0V	
OPERATING TEMPERATURE RANGE	:-20° C TO +60° C	
TEST VOLTAGE	:AT 4.8V	AT 6.0V
OPERATING SPEED	:0.17sec/60° AT NO LOAD	0.13sec/60° AT NO LOAD
OPERATING TORQUE	:3kg.cm(41.66oz.in)	3.5kg.cm(48.60 oz.in)
STANDING TORQUE	:6kg.cm(83.32oz.in)	7kg.cm(97.21 oz.in)
OPERATING ANGLE	:40°/ONE SIDE PULSE TRAVELING 400usec	
DIRECTION	:CLOCK WISE/PULSE TRAVELING 1500 TO 1900usec	
IDLE CURRENT	:3mA	3mA
RUNNING CURRENT	:180mA	230mA
DEAD BAND WIDTH	:1usec	
CONNECTOR WIRE LENGTH	:300mm(11.81in)	
DIMENSIONS	:30x10x34mm(1.18x0.39x1.33in)	
WEIGHT	:24g(0.84oz)	

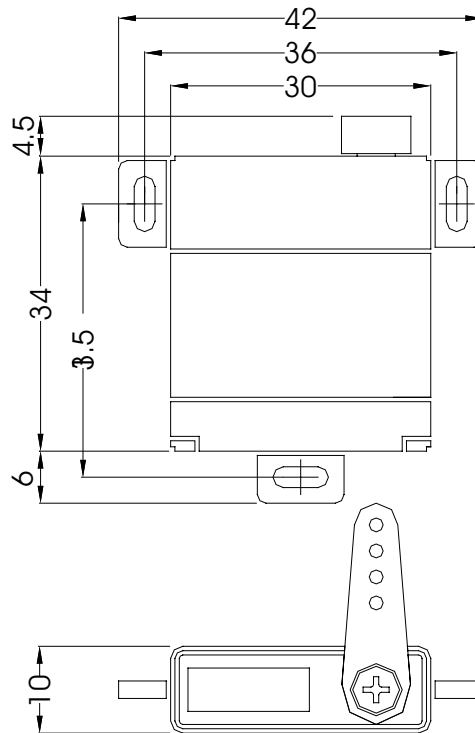

2. FEATURES

- DIGITAL & MOS FET AMP
- PROGRAMBLE
- 3-POLE FERRITE MOTOR
- LONG LIFE POTENTIOMTER
- NARROW DEAD BAND WIDTH AND HIGH STANDING TORQUE
- GOLD PLATED CONTACTS
- DUAL BALL BEARING
- 4 METAL GEAR & METAL RESIN GEAR
- METAL SPLINED HORN

3. APPLICATIONS

- GLIDER WINGS

